

AIRJET

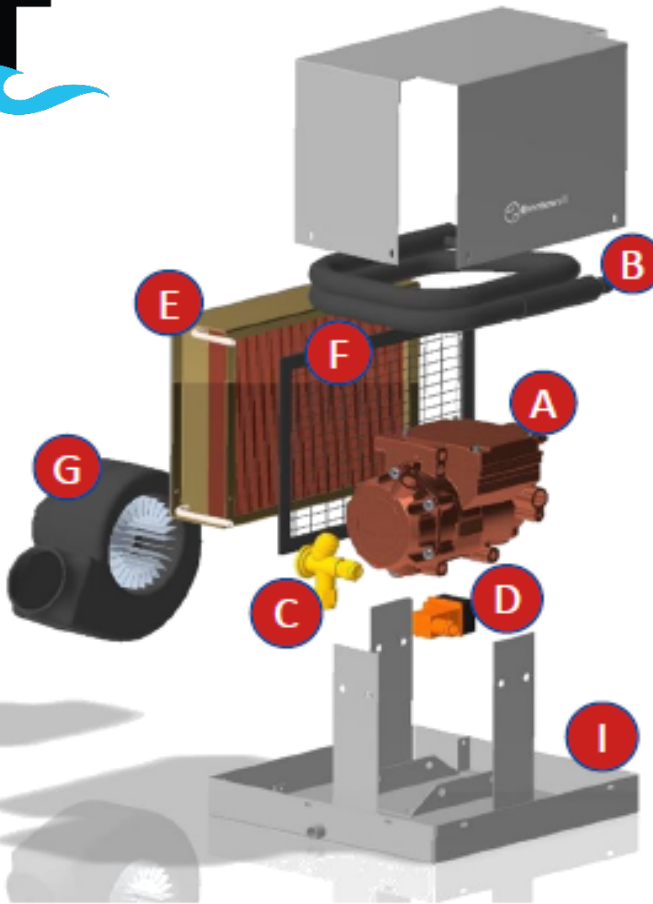

AirJet12 Components



A Semi-hermetic scroll compressor with aluminum brushless motor, suitable for maritime environment



B Cupronickel condenser piping



C Thermostatic valve



D High pressure switch



E Exchanger



F Air filter



G Fan



H Display and remote control (optional)



I Stainless steel condensate drain pan

Specifications

Description	Detail
Nominal Cooling BTU/h	Low: 3700 High: 6100
Nominal Cooling Capacity (W)	Low: 1080 High: 1780
Power Supply	12V DC
Full Load (FLA) A/h	Low: 40 High: 60
Power Input Kw	Low: 0.6 High: 0.8
Refrigeration Charge	190grms
Blower Diameter	80mm
Air Flow mc/h	500
Sea Water Connections mm	18
Water Flow	Low: 6 High: 7.5
Compressor	Scroll BLDC
Wiring Diameter mm	10
Net Weight kg	17
Sizes self-contained version LXD _X H mm	380x500x240

Standard Accessories Kit



- Flexible insulated duct diam. 82mmx1.5mm
- PVC circular white round closable supply grille diam. 100mm
- PVC hose clamps 400x8mm (2)
- White Return air grille diam. 300c200mm
- In line junction 100-80mm
- PVC Hose with spiral reinforcement 20mm (3m)
- Sea Water Plastic strainer
- Male hose connector ½"x20mm
- Ball Valve ½" female/female
- Sea water intake ½"
- Sea Water discharge ½"
- Stainless steel hose clamps 17x32mm (8)
- Condensate drainpipe (1.5m)
- Angular steel brackets (3)

Installation Scheme

